

1 hoved for rensenål 30 ϕ x 12
bl. st.

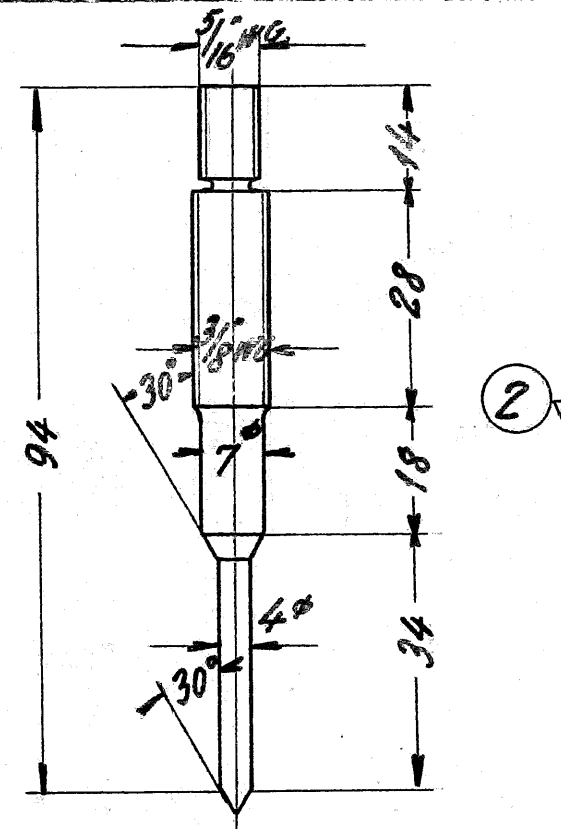

2 rensenål 10 ϕ x 92
rustfrit st.

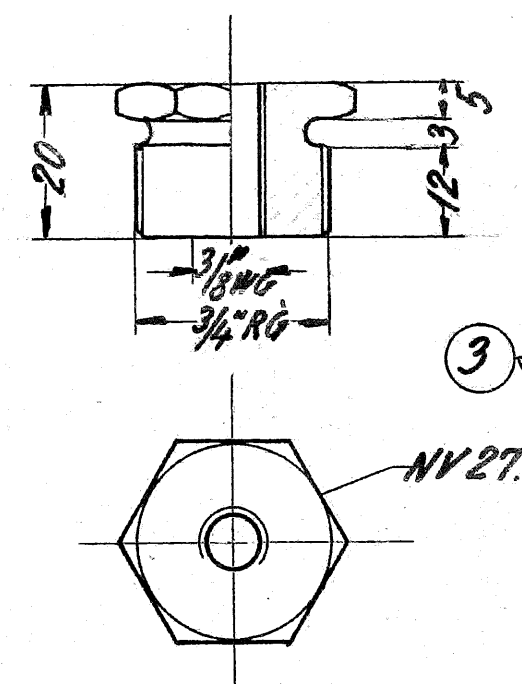

3 pakbøsning NV 27 x 20
st. 34.

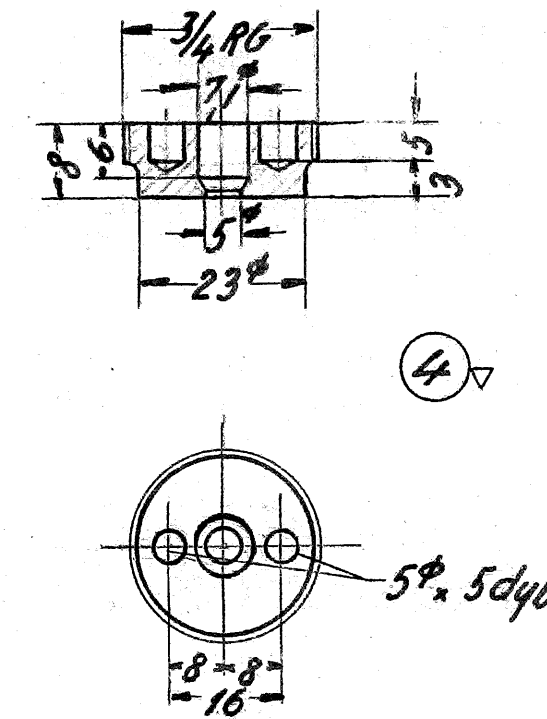

4 bundstyr 3/4" RG x 8
metal

Pos 6 3/4" tee-slyk, opspændes på gevinddorn
og udbores til 23 ϕ H.

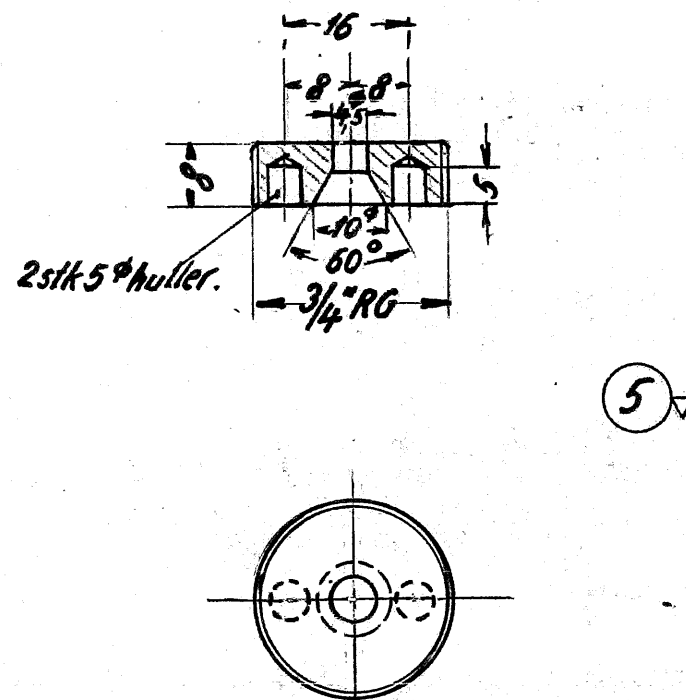

5 dyse 3/4" RG x 8
rustfrit stål.

1	pakmellopakning	7	pakmel	8 x 8 x 7.5
1	tee 3/4"	6	GF 130	magasin.
1	dyse	5	rustfrit stål.	28 ϕ x 15
1	bundstyr	4	metal.	28 ϕ x 15
1	pakbøsning	3	st. 34	NV 27 x 25.
1	rensenål	2	rustfrit stål.	10 ϕ x 100
1	hoved for rensenål	1	bl. st.	30 ϕ x 17.

Sik.	Betegnelse	Pos.	Materiale kvalitet	Model nr. eller materiale størrelse	rå vægt/sik.	færdig vægt/sik.

Danske Statsbaner.
Maskinafdelingen.

Malestok
1:1
Tegn. Nr. 13W-2.130b
Indr.
Date

Dyse for
doseringsanlæg Nalco.
Diesel-el. 500/550 hk. motorvogn.

MO 13.557

Ltr. Mo. 1821-

FRICHS 17 140

Ltr. Mo. 1821-

MO 13.557